

MasoneilanTM 71000 Series Streamlined Angle Valve

Instruction Manual (Rev.B)

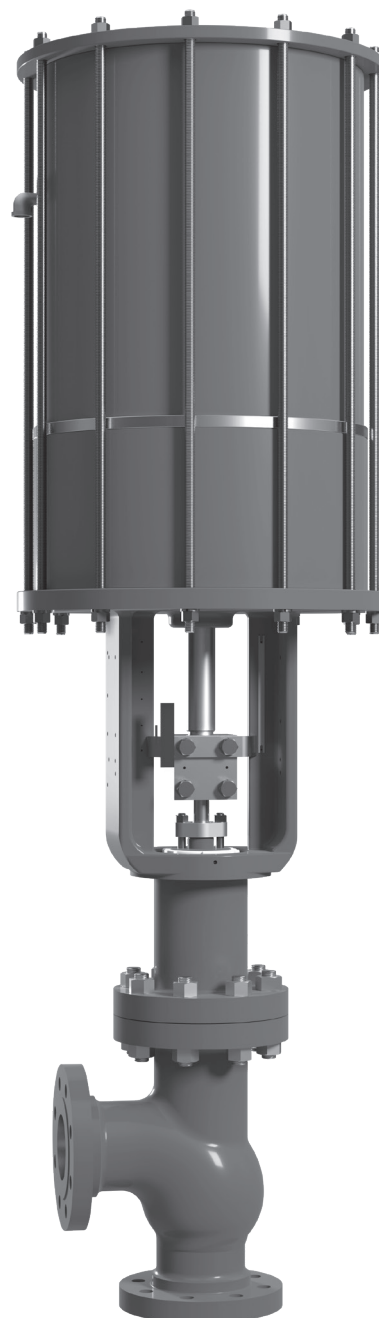

THESE INSTRUCTIONS PROVIDE THE CUSTOMER/OPERATOR WITH IMPORTANT PROJECT-SPECIFIC REFERENCE INFORMATION IN ADDITION TO THE CUSTOMER/OPERATOR'S NORMAL OPERATION AND MAINTENANCE PROCEDURES. SINCE OPERATION AND MAINTENANCE PHILOSOPHIES VARY, BAKER HUGHES COMPANY (AND ITS SUBSIDIARIES AND AFFILIATES) DOES NOT ATTEMPT TO DICTATE SPECIFIC PROCEDURES, BUT TO PROVIDE BASIC LIMITATIONS AND REQUIREMENTS CREATED BY THE TYPE OF EQUIPMENT PROVIDED.

THESE INSTRUCTIONS ASSUME THAT OPERATORS ALREADY HAVE A GENERAL UNDERSTANDING OF THE REQUIREMENTS FOR SAFE OPERATION OF MECHANICAL AND ELECTRICAL EQUIPMENT IN POTENTIALLY HAZARDOUS ENVIRONMENTS. THEREFORE, THESE INSTRUCTIONS SHOULD BE INTERPRETED AND APPLIED IN CONJUNCTION WITH THE SAFETY RULES AND REGULATIONS APPLICABLE AT THE SITE AND THE PARTICULAR REQUIREMENTS FOR OPERATION OF OTHER EQUIPMENT AT THE SITE.

THESE INSTRUCTIONS DO NOT PURPORT TO COVER ALL DETAILS OR VARIATIONS IN EQUIPMENT NOR TO PROVIDE FOR EVERY POSSIBLE CONTINGENCY TO BE MET IN CONNECTION WITH INSTALLATION, OPERATION OR MAINTENANCE. SHOULD FURTHER INFORMATION BE DESIRED OR SHOULD PARTICULAR PROBLEMS ARISE WHICH ARE NOT COVERED SUFFICIENTLY FOR THE CUSTOMER/OPERATOR'S PURPOSES THE MATTER SHOULD BE REFERRED TO BAKER HUGHES.

THE RIGHTS, OBLIGATIONS AND LIABILITIES OF BAKER HUGHES AND THE CUSTOMER/OPERATOR ARE STRICTLY LIMITED TO THOSE EXPRESSLY PROVIDED IN THE CONTRACT RELATING TO THE SUPPLY OF THE EQUIPMENT. NO ADDITIONAL REPRESENTATIONS OR WARRANTIES BY BAKER HUGHES REGARDING THE EQUIPMENT OR ITS USE ARE GIVEN OR IMPLIED BY THE ISSUE OF THESE INSTRUCTIONS.

THESE INSTRUCTIONS ARE FURNISHED TO THE CUSTOMER/OPERATOR SOLELY TO ASSIST IN THE INSTALLATION, TESTING, OPERATION, AND/OR MAINTENANCE OF THE EQUIPMENT DESCRIBED. THIS DOCUMENT SHALL NOT BE REPRODUCED IN WHOLE OR IN PART WITHOUT THE WRITTEN APPROVAL OF BAKER HUGHES.

Table Of Contents

Safety Information	1
About this Manual	1
1. General	2
1.1 Field of Application	2
1.2 Serial Plate	2
1.3 After Sales Service	2
1.4 Spare Parts	2
1.5 Actuator and Other Accessories	2
2. Installation	2
2.1 Cleanliness of Piping	2
2.2 Isolating By-Pass Valve	2
2.3 Heat Insulation	2
2.4 Hydraulic Test and Cleaning of Lines	2
2.5 Flow Direction	2
3. Maintenance	3
3.1 Disassembly	3
3.2 Reassembly	3
Tightening Torque	4
Parts Reference Diagram	5
3.3 Packing Box	6
3.4 Plug Stem Pinning	6

Safety Information

Important - Please read before installation

These instructions contain **DANGER**, **WARNING**, and **CAUTION** labels, where necessary, to alert you to safety related or other important information. Read the instructions carefully before installing and maintaining your control valve. **DANGER** and **WARNING** hazards are related to personal injury. **CAUTION** hazards involve equipment or property damage. Operation of damaged **equipment can, under certain operational conditions, result in degraded process system performance that can lead to injury or death. Total compliance with all DANGER, WARNING, and CAUTION notices is required for safe operation.**



This is the safety alert symbol. It alerts you to potential personal injury hazards. Obey all safety messages that follow this symbol to avoid possible injury or death.



Indicates a potentially hazardous situation which, if not avoided, could result in death or serious injury.



Indicates a potentially hazardous situation which, if not avoided, could result in serious injury.



Indicates a potentially hazardous situation which, if not avoided, could result in minor or moderate injury.



When used without the safety alert symbol, indicates a potentially hazardous situation which, if not avoided, could result in property damage.

Note: Indicates important facts and conditions.

About this Manual

- The information in this manual is subject to change without prior notice.
- The information contained in this manual, in whole or part, shall not be transcribed or copied without Baker Hughes's written permission.
- Please report any errors or questions about the information in this manual to your local supplier.
- These instructions are written specifically for the 71000 Series Steamlined Angle Valves, and do not apply for other valves outside of this product line.

Useful Life Period

The current estimated useful life period for the 71000 Series Steamlined Angle Valves is 25+ years. To maximize the useful life of the product, it is essential to conduct annual inspections, routine maintenance and ensure proper installation to avoid any unintended stresses on the product. The specific operating conditions will also impact the useful life of the product. Consult the factory for guidance on specific applications if required prior to installation.

Warranty

Items sold by Baker Hughes are warranted to be free from defects in materials and workmanship for a period of one year from the date of shipment provided said items are used according to Baker Hughes recommended usages. Baker Hughes reserves the right to discontinue manufacture of any product or change product materials, design or specifications without notice.

Note: Prior to installation

- The valve must be installed, put into service and maintained by qualified and competent professionals who have undergone suitable training.
- All surrounding pipe lines must be thoroughly flushed to ensure all entrained debris has been removed from the system.
- Under certain operating conditions, the use of damaged equipment could cause a degradation of the performance of the system which may lead to personal injury or death.
- Changes to specifications, structure, and components used may not lead to the revision of this manual unless such changes affect the function and performance of the product.

1. General

1.1 Field of Application

The following instructions are designed to guide the user during the installation and maintenance of 71000 Series Steamlined Angle Valves.

1.2 Serial Plate

This plate is usually fixed on the side of the actuator yoke. It indicates the valve type, model number, serial number, pressure class, pressure shell material, actuator pressure supply, and other necessary information.

1.3 After Sales Service

Baker Hughes has a highly skilled After Sales Department available for start-up, maintenance and repair of our equipment. Contact the nearest Baker Hughes local representative or After Sales Department.

1.4 Spare Parts

For maintenance always use only original spare parts obtained through your local Baker Hughes representative or Spare Parts Department.

When ordering spare parts, the model and serial numbers indicated on the manufacturer's serial plate must be provided to the Baker Hughes representative.

1.5 Actuator and Other Accessories

The valve is normally equipped with an actuator. There is a particular instruction manual for each actuator, as well as for all other accessories installed on the valve assembly. Consult this actuator instruction manual for electrical and air connections. The references of instructions for standard actuators are the following: 31188 for the 51/52/53 types, 19530 for the 87/88 types.

Note: This manual describes all standard options of the 71000 Series valves. In order to meet the particular requirements of your application, Baker Hughes may have developed a special option covered by an Appendix to the present manual. If this is the case, the instructions of this Appendix always prevail over the general manual instructions.

2. Installation

2.1 Cleanliness of Piping

Before installing the valve in the line, clean piping and valve of all foreign material such as welding debris, scale, oil, grease or dirt. Gasket surfaces must be thoroughly cleaned to insure leak-free joints.

2.2 Isolating By-Pass Valve

To allow for in-line inspection, maintenance and removal of the valve without service interruption, provide a manually operated stop valve on each side of the control valve and a manually operated throttling valve in the by-pass line.

2.3 Heat Insulation

In case of heat insulated installation, do not insulate the valve bonnet and take protection measures related to personal safety.

2.4 Hydraulic Test and Cleaning of Lines

During this operation, the control valve must not be used as an isolating valve. This means that the valve must always be opened before carrying out pressure tests in the process line, or cleaning of pipes, etc., to avoid any damage to seal rings and equipment.

2.5 Flow Direction

The valve must be installed so that the controlled substance will flow through the valve in the direction indicated by the flow arrow located on the body.

3. Maintenance

If it is necessary to disassemble the valve for cleaning, maintenance or replacement of a damaged part, proceed as follows:

3.1 Disassembly

- Depressurize the line and stroke the valve to mid-travel.
- Separate the valve from the line and make sure that the body is depressurized. Remove the valve from piping.
- Unscrew the packing stud nuts (B028) in order to reduce the packing adhesion to the plug stem.
- Disconnect the plug stem (B008) from the actuator stem.
- Remove the yoke nut (B013) and separate the actuator with its yoke from the bonnet (B034).
- Unscrew the bonnet stud nuts (B032) and remove them together with the bonnet studs (B033), lift up the bonnet (B034) until it gets free from the end of the plug stem (B008).
- Remove the guide gasket (B010) (size 8", 10" and 12" only) and remove the plug stem (B008). If this operation becomes difficult because of residues of solidified hydrocarbons present on the parts, replace the bonnet supported only with four bolts with nuts situated one pair opposite the other, then leaning on a flat bar iron and a cylindrical distance piece set on the top of the bonnet, turn a nut which has been screwed previously on the plug stem in order to "unstick" the plug and the guide (B006), then lift them off slowly either together or separately.
- Remove the bonnet. Pull out the plug with its stem as well as the plug guide (B006) and separate them if necessary. Remove the gasket (B009); pull out the packing (B011).
- Unscrew the seat ring retainer (B001) and remove the seat ring (B002). Thoroughly clean all of the parts before reassembling.

3.2 Reassembly

- Replace all parts with significant dimensional defects caused by the corrosion, erosion or wear. It is also recommended to replace the gasket (B009), the guide gasket (B010) and the packing (B011) with new parts after each disassembly.
- Replace the seat ring (B002) in the valve body. Screw and lock the seat ring retainer (B001) with torque value indicated in the table below for each valve size.

Note: A sealant compatible with the process should be applied sparingly on the retainer thread.

- Insert the plug guide (B006) in the valve body following with the plug (B005) fitted with its stem (B008). Place the gasket (B009) on the body.

CAUTION

For bonnet with purge or injection connection: NPT or flange. Before achieving metal to metal contact with the body, rotate the bonnet to orient this connection in front of the existing piping.

Center the guide gasket (B010) on the top of the guide (B006), and then place the bonnet down over the plug stem until it is centered on the upper part of the guide.

- Assemble the bonnet with the body by means of bonnet studs (B033) and bonnet stud nuts (B032). Tighten the nuts to obtain metal-to-metal contact between the bonnet and valve body (size 8", 10" and 12" only) and/or tighten them with torque value indicated in the table below for each valve size.
- Insert the packing as follows: first, one braided ring, then the die-formed rings and finally another braided ring. It is important to tamp down the rings in the packing box one by one. If packing rings have a radial cut, stagger the cut of adjacent rings by 180°.
- Slip the packing follower and flange over the plug stem. Tighten the nuts (B028) manually. Verify if the plug accomplishes its normal stroke in the valve body. Tighten the nuts (B028) to another full turn with the wrench.
- Replace the actuator and fasten it by means of the yoke nut (B013).
- Be sure that the plug sits normally on the seat ring and connect the actuator to airline or to electrical circuit.
- Connect the actuator stem to the valve stem in accordance with the appropriate actuator instruction manual.
- Replace the valve on the piping, carry out the connections and start it up again.

Tightening Torque

Valve Size		ANSI Class Max.	Body Studs		Required Torque			
					Carbon Steel Body Studs		Retainer Seat Ring	
mm	in.		Size	Qty	Ft. Lbs	daN.m	Ft. Lbs	daN.m
25	1	600	1/2 - 13 UNC	4	52	7	148	20
40	1 1/2	600	3/4 - 10 UNC	4	118	16	148	20
50	2	600	5/8 - 11 UNC	8	96	13	221	30
80	3	600	3/4 - 10 UNC	8	170	23	1475	200
100	4	600	7/8 - 9 UNC	8	295	40	3690	500
150	6	600	1 - 8 UN	12	288	39	4425	600
200	8	600	1 3/8 - 8 UN	12	605	82	4425	600
250	10	600	1 1/4 - 8 UN	16	443	60	11065	1500
300	12	600	1 1/4 - 8 UN	16	443	60	11065	1500

Parts Reference Diagram

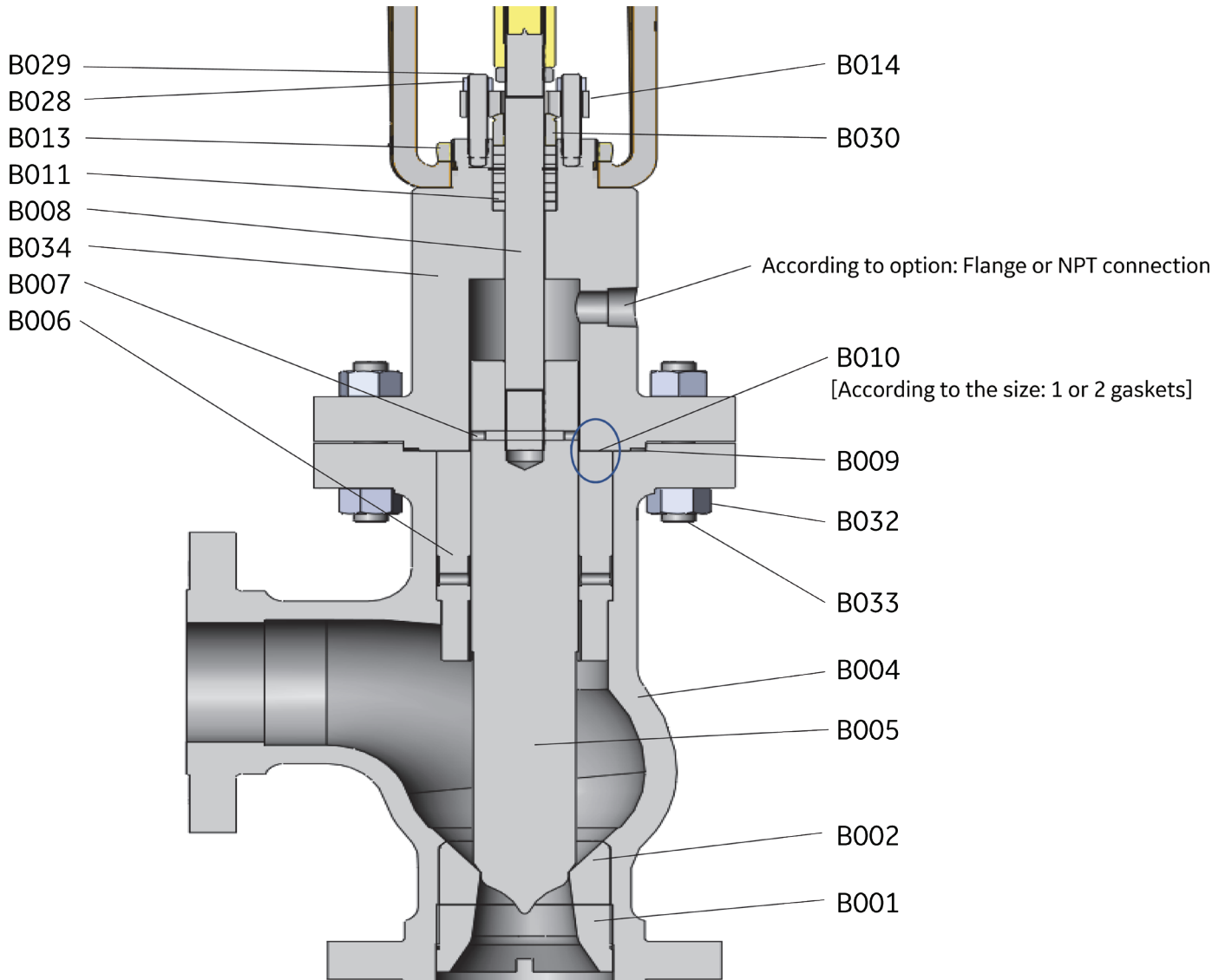

3.3. Parts List

Item	Designation	Item	Designation
B001	Seat ring retainer	B011	Packing rings
B002	Seat ring	B013	Yoke nut
B004	Valve body	B014	Packing flange
B005	Valve plug	B028	Packing stud nut
B006	Plug guide	B029	Packing stud
B007	Plug stem pin	B030	Packing follower
B008	Plug stem	B032	Bonnet stud nut
B009	Valve body gasket	B033	Bonnet stud
B010	Guide gasket (8, 10 and 12 sizes only)	B034	Bonnet

3. Maintenance (cont.)

3.3 Packing Box

The constant supervision of the packing box is one of the main routing operations of the maintenance service. In order to provide a correct functioning of the valve, the packing should not be tightened over the compression value sufficient to provide the tightness. The packing box efficiency is obtained by the compression of the packing, or by combining it with use of the lubricant. As it wears, gradually re-tighten the packing up to the limits of the possible compression. In order to add packing, it is necessary only to remove the packing follower and flange and introduce one or two split rings.

Note: In case of urgency, the braided packing of suitable section can be inserted without removal of the worn rings. Before this operation, the valve must be put out of service. If the packing is made up of non-split rings, it may be necessary to disassemble the valve and remove the worn packing. To repack the stuffing box, see paragraph "Reassembling".

3.4 Plug Stem Pinning

The valve plug and the plug stem can be supplied as spare parts. If their installation in the valve does not cause any problem they are delivered in the assembled condition.

If the assembling of the plug stem on the plug has to be carried out on site, it is preferable to use a new stem. It is true that the original pinhole of a stem reused frequently makes it difficult to obtain the satisfactory results, and can reduce the mechanical resistance of the stem-and-plug assembly. Use of a new stem is preferred.

! CAUTION

Do not damage the bearing and guiding surfaces of the valve plug during the pinning operation.

The worn pin is normally removed by means of pin-punch.

! CAUTION

Do not damage the surfaces of the guides when tightening the valve plug between gripping jaws.

In order to drill the stem for pinning, place the plug in such a way that its end rests on V-blocks. Before drilling, tightly engage the stem into the threaded plug hole. It may be easily verified as follows: you have to first measure the guiding length X in the plug end, then transfer and mark this length on the stem (see the figure below).

If the assembly is done correctly, the mark makes flush with the tip of the plug end. Then the stem can be drilled taking as a guide the original hole in the plug end. First use a drill of a suitable diameter, then a reamer to make the hole diameter to the size required for inserting the pin. Thoroughly flush metal debris, and remove the sharp edges at the hole input, then lightly grease this feature before inserting the pin. The hole diameter must be sufficiently large to manually introduce the pin tip. To correctly insert the pin, hold the plug in a vise using soft jaws to prevent surface damage. Verify that the pin is sufficiently driven in, i.e., its tip has to be set back about 1.5 mm from the surface of the guiding end.

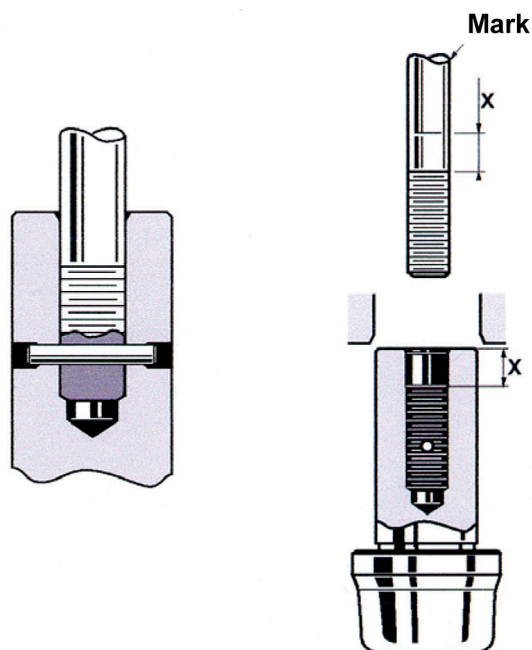

Notes

Notes

Direct Sales Office Locations

Australia

Brisbane
Phone: +61-7-3001-4319

Perth
Phone: +61-8-6595-7018

Melbourne
Phone: +61-3-8807-6002

Brazil

Phone: +55-19-2104-6900

China

Phone: +86-10-5738-8888

France

Courbevoie
Phone: +33-1-4904-9000

India

Mumbai
Phone: +91-22-8354790

New Delhi

Phone: +91-11-2-6164175

Italy

Phone: +39-081-7892-111

Japan

Tokyo
Phone: +81-03-6871-9008

Korea

Phone: +82-2-2274-0748

Malaysia

Phone: +60-3-2161-03228

Mexico

Phone: +52-55-3640-5060

Russia

Veliky Novgorod
Phone: +7-8162-55-7898

Moscow

Phone: +7-495-585-1276

Saudi Arabia

Phone: +966-3-341-0278

Singapore

Phone: +65-6861-6100

South Africa

Phone: +27-11-452-1550

**South & Central
America and the Caribbean**

Phone: +55-12-2134-1201

Spain

Phone: +34-935-877-605

United Arab Emirates

Phone: +971-4-8991-777

United Kingdom

Phone: +44-7919-382-156

United States

Houston, Texas
Phone: +1-713-966-3600

Find the nearest local Channel Partner in your area:

valves.bakerhughes.com/contact-us

Tech Field Support & Warranty:

Phone: +1-866-827-5378
valvesupport@bakerhughes.com

valves.bakerhughes.com

Copyright 2020 Baker Hughes Company. All rights reserved. Baker Hughes provides this information on an "as is" basis for general information purposes. Baker Hughes does not make any representation as to the accuracy or completeness of the information and makes no warranties of any kind, specific, implied or oral, to the fullest extent permissible by law, including those of merchantability and fitness for a particular purpose or use. Baker Hughes hereby disclaims any and all liability for any direct, indirect, consequential or special damages, claims for lost profits, or third party claims arising from the use of the information, whether a claim is asserted in contract, tort, or otherwise. Baker Hughes reserves the right to make changes in specifications and features shown herein, or discontinue the product described at any time without notice or obligation. Contact your Baker Hughes representative for the most current information. The Baker Hughes logo and Masoneilan are trademarks of Baker Hughes Company. Other company names and product names used in this document are the registered trademarks or trademarks of their respective owners.

Baker Hughes 